

12955 Enterprise Way
Bridgeton, MO 63044-1200

Technical Service (888)GPL-LINE
Parts (800) 621-7278
Parts Fax (800) 531-2580
General Information (800) 325-8811

Issue 107

December 9, 1998

A tray extension harness (P/N 1709018) has been developed to allow operation of trays outside of the machine cabinet.

Tie wraps have been added to all tray harnesses to eliminate the tendency of the wires to squeeze out of the slot in the Heyco Flex V. All current production harnesses include this change. A ribbed sleeve has also been added to protect harness wires and improve appearance.

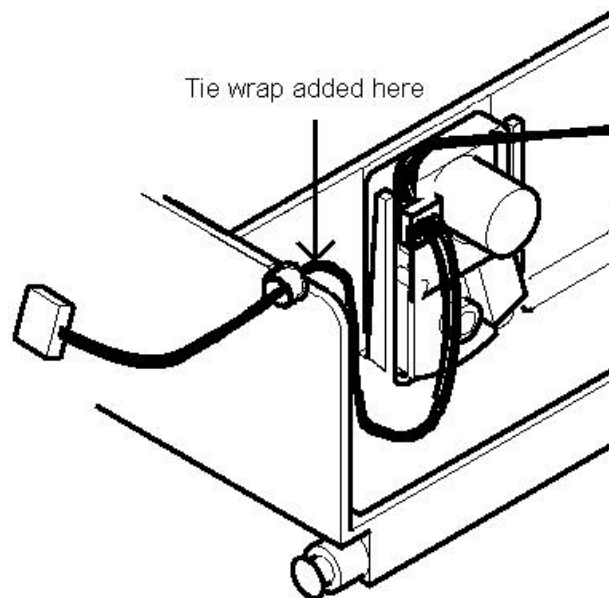

Scott Kearns